

REDLINE Asphalt & Concrete Cutter

RC185D

Technical Data

Masses

| | |
|----------------|--------|
| Net mass | 168 kg |
| Operating mass | 188 kg |

Cutting Section

| | |
|------------------------|---------|
| Diamond Blade, max. | 510 mm |
| Max. Cutting depth | 185 mm |
| Spindle diameter | 25.4 mm |
| Water tank capacity, l | 40 l |

Engine

| | |
|--------------------|--------------|
| Manufacturer Model | Greaves 1510 |
| Type | Diesel |
| Power | 6.1 kW |

Dimensions

| | |
|-----------|----------|
| Height H | 1,115 mm |
| Length L | 1,176 mm |
| Length L1 | 1,520 mm |
| Width W | 585 mm |

Blades

| | |
|----------------------|------------------|
| Standard blade | 510 mm |
| Optional blade sizes | 350, 450, 500 mm |



Features

- Electric starter for effortless ignition
- Integrated rust-resistant large water tank
- Robust quick-connect water spray system
- Four banded, cogged V-belts designed for Complete V-belt protection
- Single-point lifting mechanism
- Precise and controlled cutting depth for accurate results

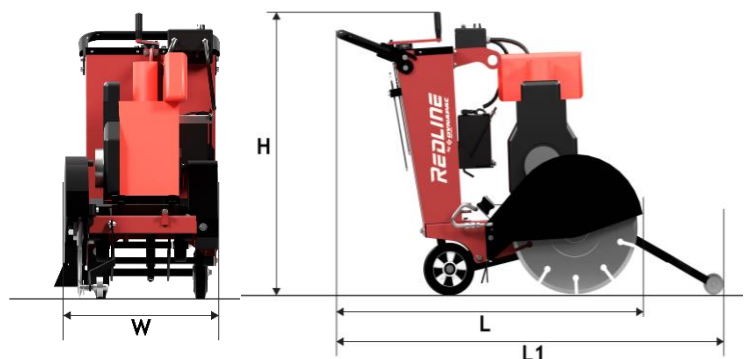

We reserve right to change specifications without notice. Photos and illustrations do not always show standard versions of machines.

The above information is a general description only, all information are supplied without liability.

