

RedLINE

by **DYNAPAC**
FAYAT GROUP

REDLINE

SMALL TANDEM ROLLER



DRA30

DRA30 small tandem roller at a glance

Easy, compact and efficient- The DRA30 combines high quality results, low noise and efficiency compaction.

Rely on the performance of the DRA30, independant from the asphalt mix. And the great operator visibiliy and ergonomics ensure a high quality level, even in demanding situations.

Operating mass (incl. ROPS)	3100 kg
Max. operating mass	3200 kg
Static linear load (front/rear)	12.5 / 13.3 kg/cm
Max. operating mass (front/rear)	1500 kg/1600 kg
Drum width	1200 mm
Nominal amplitude	0.5 mm
Vibration frequency	58 Hz
Engine type	Dynapac
Engine rated power @2600 rpm	39 hp

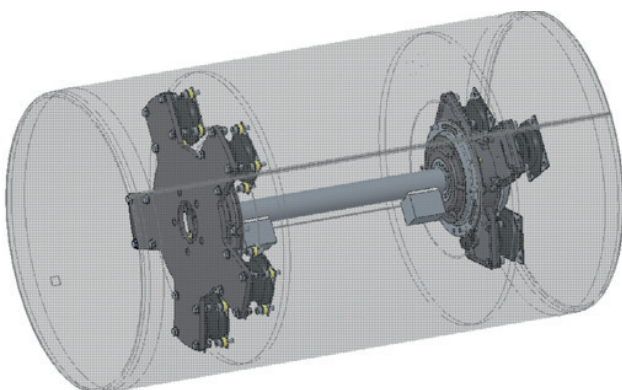

Reliable and efficient compaction

Ideal combination of amplitude, frequency & centrifugal force for optimum compaction, excellent surface finish and high productivity.

Two scrapers per drum ensure that no material sticks to the drum.

Adjustable scrapers makes it convenient to change gap between the drum and the blade according to the needs.



Ergonomic & simple operators dashboard

- Ergonomically laid out controls and informative display
- Lean design for easy operation
- Informative and robust display in the center of the dashboard



Reliable Dynapac engine for maximum uptime

- All service and parts fully provided by Redline dealer network
- Quick responses through dedicated Redline dealer network
- 3 cylinder water cooled engine
- 39 hp @ 2600rpm



High quality results due to ergonomic operator platform

- Ergonomic forward and reverse handle
- Spacious operator platform with ergonomically positioned steps
- An interlock system prevents accidental engine starting



Excellent overview to concentrate on the job

- Operator platform ensures best all-around visibility
- Front and rear visibility is best in class
- 1 m high x 0.44 m away from machine front and rear objects can be seen from seat



Wide hood opening and clever service concept for easy maintenance

- Safe and easy access to engine compartment
- Easy to fill water tank- with 160 l capacity
- Access from the ground for easy refills
- Triple filtration sprinkler system with filling cap filter, sprinkler pump filter & nozzle filter



DYN@LINK - DYNAPAC CONNECTS THE FUTURE

Dyn@Link provides customers with a tool to monitor and manage their machine fleet efficiently and conveniently. The intelligent telematics system offers many possibilities to optimize fleet usage reducing maintenance costs, saving time and money.



FLUIDS & LUBRICANTS

- Right Fluids as confirmed by product design
- Right size of packaging to avoid storage



EXTENDED WARRANTY

- Extended warranty for peace of mind
- Service agreement to ensure higher uptime



TAILOR MADE TRAININGS

- Various training modules geared towards our customer requirements

Reliable Aftermarket Support - Solutions to fit



MAINTENANCE KITS

- All-in-one box concept for ease of ordering
- Designed to cover full maintenance
- Cost effective as well as easy to plan



WEAR & REPAIR KITS

- All-in-one box package for ease of ordering
- Right quality at right cost, for minimum cost of operation
- Different options to suit all maintenance

Dealership Details

